



Air purification and disinfection devices for ventilation systems

NingBo AIPRO Environmental Technology Co.,Ltd

Company profile

The company was established in 1997, and located in Zhengjiang Ningbo. We have been working closely with Shanghai Jiao Tong University since 2002, specializing in the research and development, manufacturing, sales and technical services of air disinfection and purification products [electrostatic precipitation and photocatalysis] of central air conditioning systems. Our products are widely used in modern office buildings, medical systems, transport hub systems, cultural recreation and sports systems, hotels, and many other fields. The factory has the ability to produce tens of thousands of sets of various purification and disinfection devices per year, and we are committed to providing users with high quality product technology and services in a timely manner.



The company's R&D department and Shanghai Jiao Tong University have successively established advanced organic gas physical and chemical experiments and testing room, machine comprehensive performance experiments and testing room, microbiological experiment testing room, air purifier and central air conditioning disinfection and purification device laboratories. And jointly established the “Nano Environmental Protection Technology Joint Research and Development Center” with them, mainly engaged in the research of air pollution purification technology and materials.

		The levels of filters Comparison table			
		Europe standard	Chinese standard	International standard	American standard
Ultra-efficient	U17	EN 1822-2019	E	ISO 75(U)	Specially Ventilation filters System
	U16			ISO 70(U)	
	U15			ISO 65(U)	
	H14			ISO 60(U)	
	H13			ISO 55(U)	
	H12			ISO 50(U)	
	H11			ISO 45(H)	
	H10			ISO 40(H)	
				ISO 35(H)	
				ISO 30(E)	
Efficient	H10	EN 1822-2019	C	ISO 25(E)	Specially Ventilation filters System
	H9			ISO 20(E)	
Medium Effec	F9	EN 779-2012	B		Normally Ventilation filters System
	F8				
	F7				
	M6				
	M5				
Corase Effect	G4	EN 779-2012	A		Normally Ventilation filters System
	G3				
	G2				
	G1				

Application area

Business System

Refers to high-level office buildings, large high-grade Shopping malls, wholesale marketplace, trading places in finance, securities, and other industries, and various service Windows; Including hotels, hotels, restaurants, bars, clubs, and other sites to provide rest, food, parties, cultural entertainment, and sports activities.



Cultural system

Libraries, exhibition halls, museums, memorial halls, art galleries, cultural halls, stadiums, youth palaces, workers' cultural palaces, karaoke, dance halls, cafes, entertainment halls, and other public places established by the government or social organizations and open to the public for carrying out cultural, sports and entertainment activities.



Public transportation

Departures and arrivals of civil aviation airports; Train station, high-speed rail station, subway station waiting room and the ticket office, bus station and high-speed bus waiting room and ticket office.



Health care system

Including the health administration system at all levels, disease control system, health supervision system, maternal and child health system, disease prevention and control system, and community health service system; It is mainly distributed in the outpatient building and inpatient building areas of medical places.



Performance Cases



Amazon Building (Shanghai)



Microsoft R&D Center on Zixin Road



Shanghai Disneyland Park



2022 Olympic Winter Games



The Subway Station in Tianjin

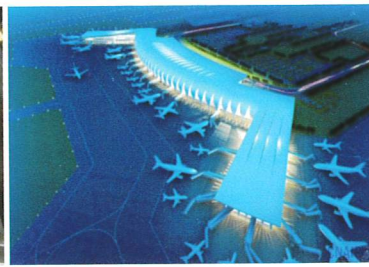

Shenyang Taoxian Airport



The Library of Tianjin University

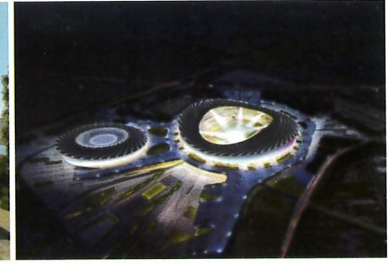

Qingdao Civic center



Shenzhen Dajiang Sky City



Shanghai Tower



Shijiazhuang First Hospital



Fuzhou Children's Hospital



Microorganism

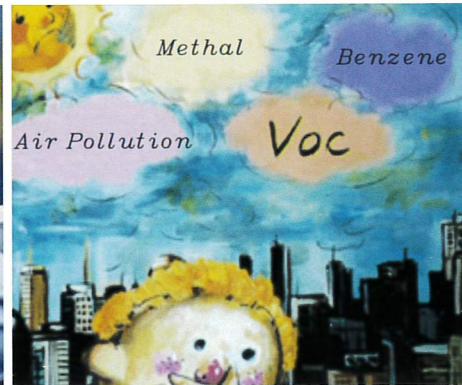

Air Pollutunt Gaseous Pollutant

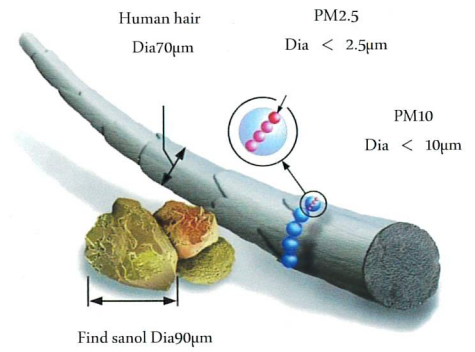

Particulate matter

Factors affecting outdoor air quality

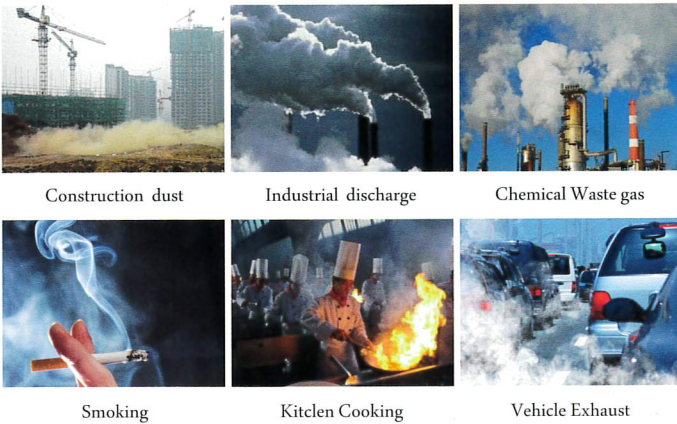

Factors affecting indoor air quality

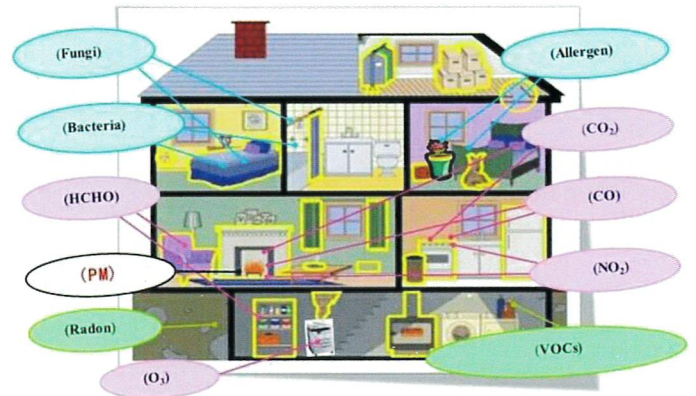

The harm of polluted air to human health

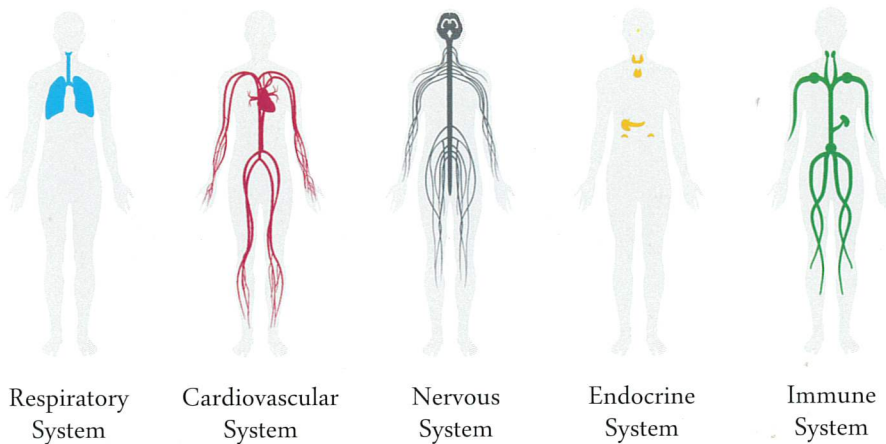

Respiratory System

Cardiovascular System

Nervous System

Endocrine System

Immune System

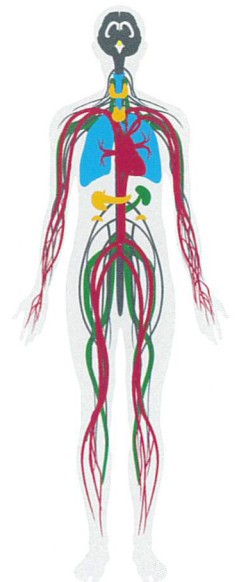

The harm of polluted air to human bodies

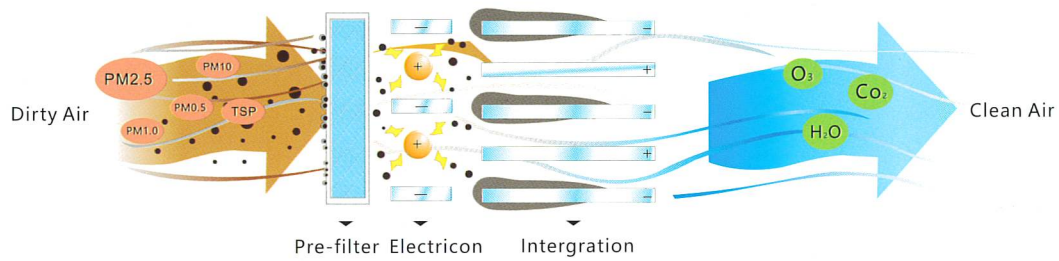

High Pressure electrostatic

The high-pressure electrostatic filter dust collector you described consists of two main sections: the ionization section and the dust collecting section. Let's discuss each section in more detail:

Ionization Section: In the ionization section, an ionization wire carries a positive DC voltage of 8000V, creating a strong electric field between the wire and the ground electrode. This electric field generates corona discharge around the ionizing wire, which ionizes the air flowing through. This process produces a large number of positive ions and electrons.

The electrons move towards the discharge wire, while the positive ions attach to the particles present in the air. This attachment of positive ions to the particles causes the particles to acquire a positive charge. As a result, the air with charged particles enters the dust collection section.

Dust Collecting Section: The dust collecting section is where most of the charged particles from the ionization section are captured. This section consists of alternating positive and negative ionization plates. A DC positive voltage of 4000V is applied to these plates, creating a uniform electric field between the plates and the ground floor.

When the positively charged particles enter this electric field, the Coulomb force acts on them, causing their direction to change. As a result, these charged particles are attracted and attached to the ground floor, effectively removing them from the air. This process not only removes dust particles but also helps in sterilizing and disinfecting bacteria and viruses present in the dust due to the high-pressure ionization environment.

In summary, the high-pressure electrostatic filter dust collector utilizes an ionization section to charge particles in the air and a dust collecting section with alternating ionization plates to attract and remove the charged particles. This process aids in dust removal as well as the sterilization and disinfection of bacteria and viruses.

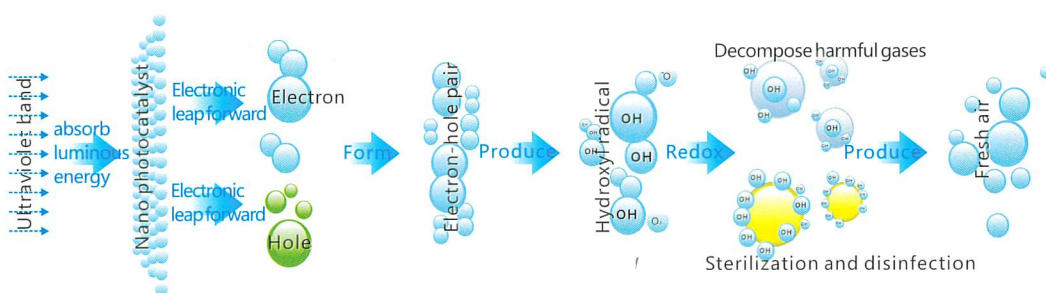

Schematic diagram of photocatalysis technology

The catalytic materials on the periphery of the metal plate are activated by UV illumination, and a variety of ions with strong oxidation ability (hydroxyl radical, oxygen group and ozone) are produced. On the one hand, it comes from the UV lamp itself, on the other hand, it from the reaction of catalytic materials, the combination of those two will produce an “avalanch” phenomenon. As a result, it generates more ions to fully decompose harmful gases (VOC) including formaldehyde, benzene, toluene, xylene, ammonia, etc. in the air. The lamp tube in our photocatalytic products produces UVC (254nm) and UVD (185nm) ultraviolet rays, which destroy the DNA and RNA of bacteria and microorganisms in the air around the products and makes them unable to reproduce and grow until they die. In conclusion, it plays a role in sterilization. However, the photocatalytic function will also decomposes the "corpse" of bacteria, viruses and microorganisms, which has the effect of removing the peculiar smell. The above process makes our photocatalytic products have the degradation of organic gases (VOC), sterilization, and odor removal effects.

Central air conditioning system air purification application diagram

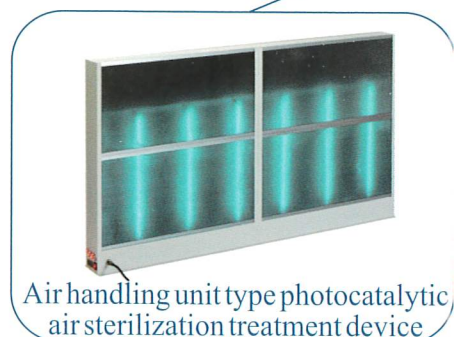
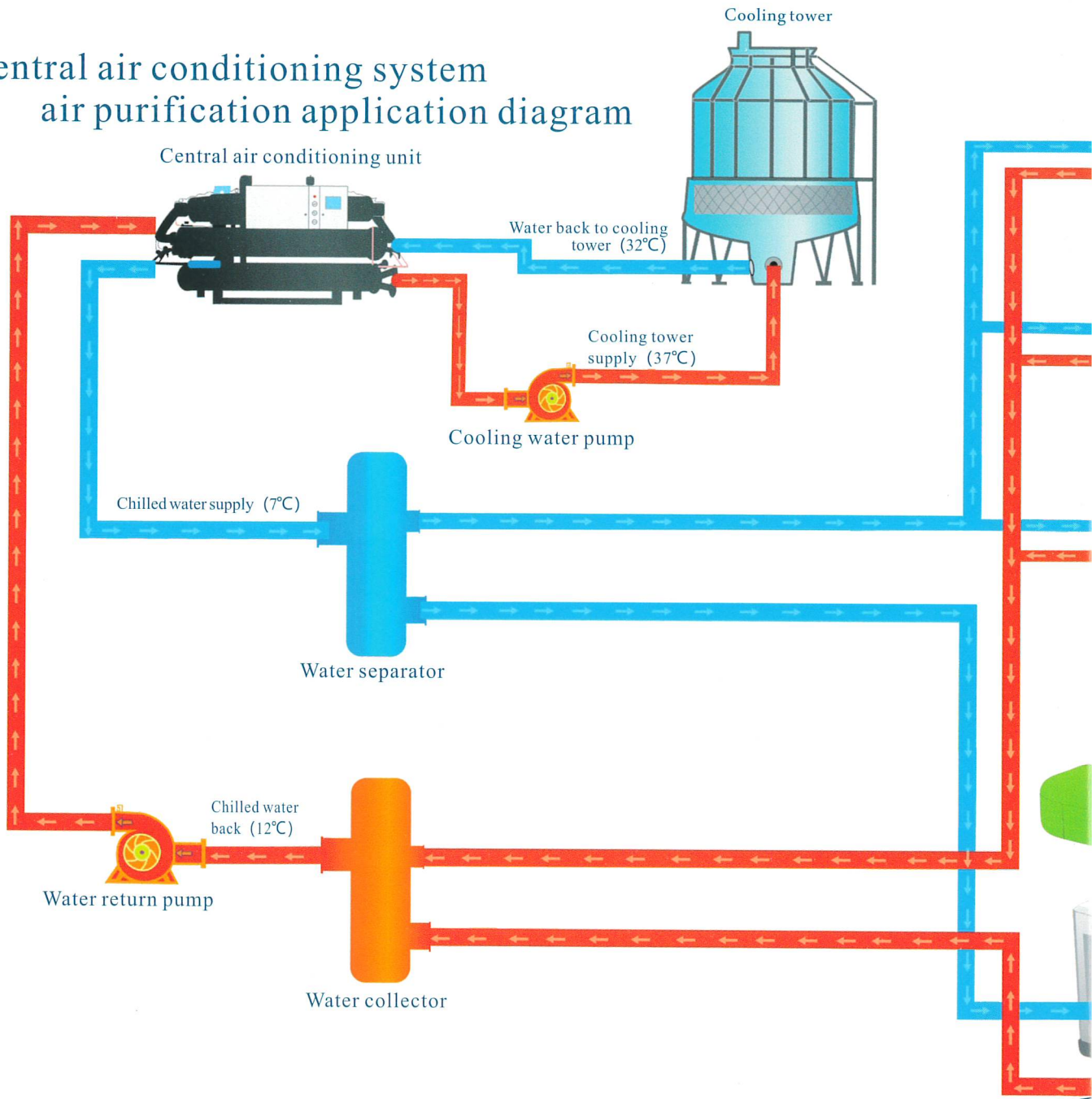

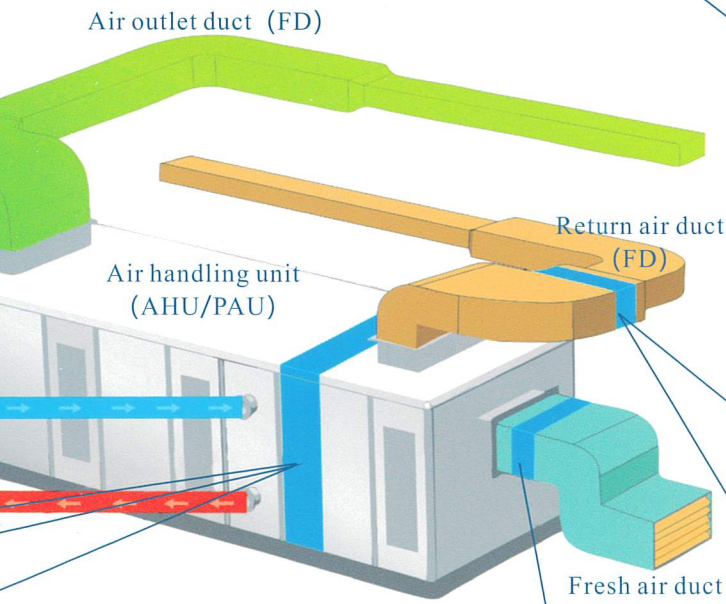
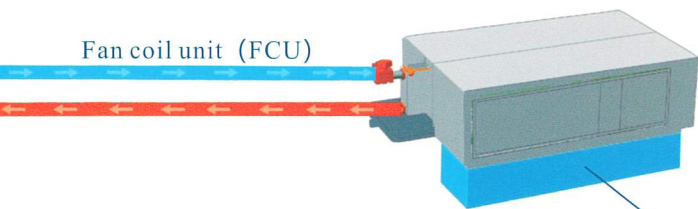
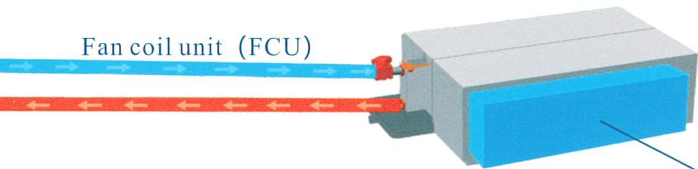
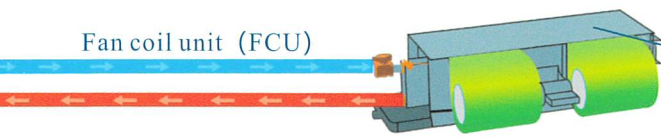

Air conditioning box type electrostatic air purification and disinfection device



Efficient purification

This product can effectively remove suspended particles in the air, such as TSP, PM10, PM2.5, cigarette smoke, pollen, bacteria, spores, and dust mites. The one-time effective removal rate of PM2.5 reaches more than 95%, the microbial killing rate can reach more than 90% under the rated air volume, and the ultra-fine particles with a diameter of 0.1 μm can be captured.

Environment protection

The dust collection modules are made of aviation aluminum and aluminum zinc plate after special process treatment, effectively preventing equipment rust. The products do not need consumables, the service life of the equipment reaches more than 15 years, and the equipment materials can be recycled.

Application

Suitable for places requiring high indoor air quality, such as AHU (air conditioning air handling unit), PAU (fan coil unit) commercial central air conditioning system, large transportation hub system, medical system, large sports system, and large business center.

Product configuration

It can run in tandem with the fan, and also can realize remote start, remote shut down, operation, fault and cleaning feedback, and building BA (building automation) system docking. At the same time, you can choose a front-effect filter or a rear-effect bag filter, which integrates the high-voltage electrostatic module with the physical filter to effectively save installation space.

Reasonable installation

A standard modular design is adopted, which is easy to assemble according to the internal space of the air conditioning box. Applicable to new construction and renovation projects.

Authoritative certification

The product has passed CE certification and CQC certification and has passed the CABR (Energy Saving and Environmental Protection) certification of the China Academy of Building Sciences.

Products Parameter

Product name	Product Model	Air volume (m³/h)	Product size(mm)			Power (w)	Weight (kg)	PM2.5	Microbial	Resistance (Pa)	Operating voltage	Working environment
			W	H	L							
Air conditioning box type electrostatic air purification and disinfection device	AP-E-835D	5000	688	835	141	30	20	≥ 90%	≥ 95%	≤ 30Pa	AC 220V 50Hz	Temperature: 1~50°C Humidity: ≤ 95%
	AP-E-835T	3700	525	835	141	25	16					
	AP-E-835S	2500	371	835	141	15	12					
	AP-E-610D	3400	688	610	141	25	15					
	AP-E-610T	2450	525	610	141	20	12					
	AP-E-610S	1700	371	610	141	12	9					
	AP-E-500D	2500	688	500	141	20	13					
	AP-E-500T	1850	525	500	141	12	10					
Air conditioning box type electrostatic air purification and disinfection device(G4)	AP-E-500S	1250	371	500	141	10	7	≥ 90%	≥ 95%	≤ 90Pa	AC 220V 50Hz	Temperature: 1~50°C Humidity: ≤ 95%
	AP-E-835D/G	5000	688	835	190	30	22					
	AP-E-835T/G	3700	525	835	190	25	18					
	AP-E-835S/G	2500	371	835	190	15	12					
	AP-E-610D/G	3400	688	610	190	25	17					
	AP-E-610T/G	2450	525	610	190	20	13					
	AP-E-610S/G	1700	371	610	190	12	10					
	AP-E-500D/G	2500	688	500	190	20	15					
AP-E-500T/G	1850	525	500	190	12	11						
AP-E-500S/G	1250	371	500	190	10	8						

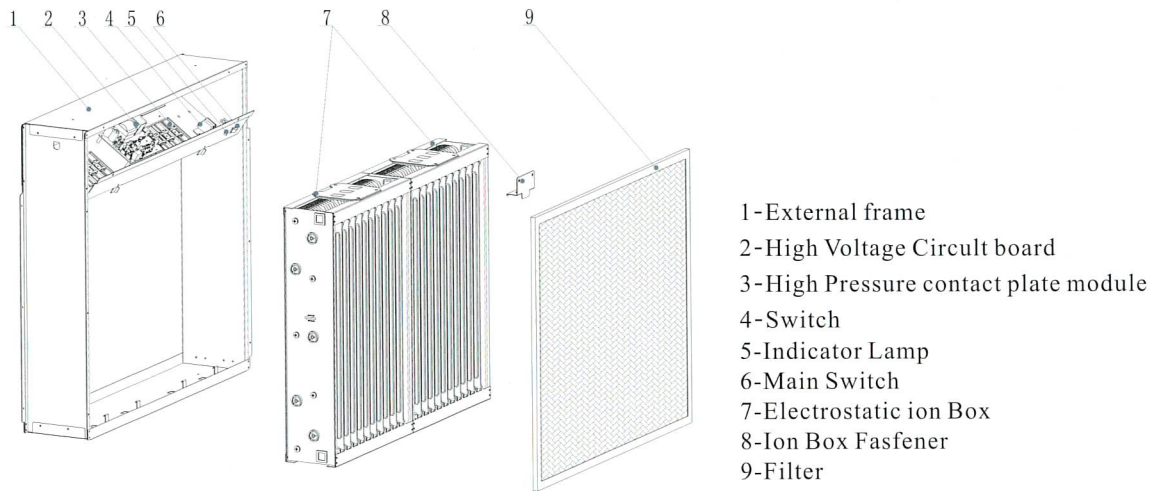

▲ Product structure

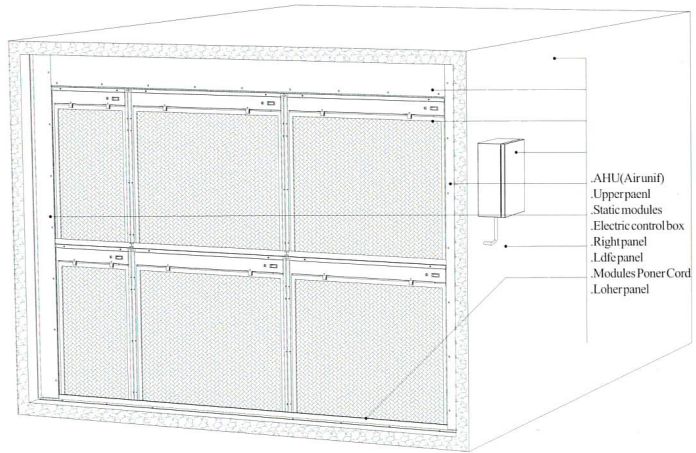
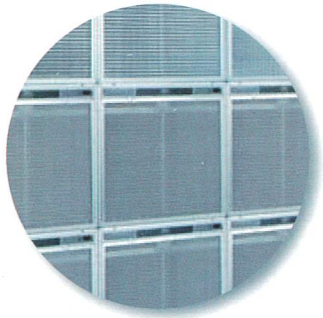

▲ Installation

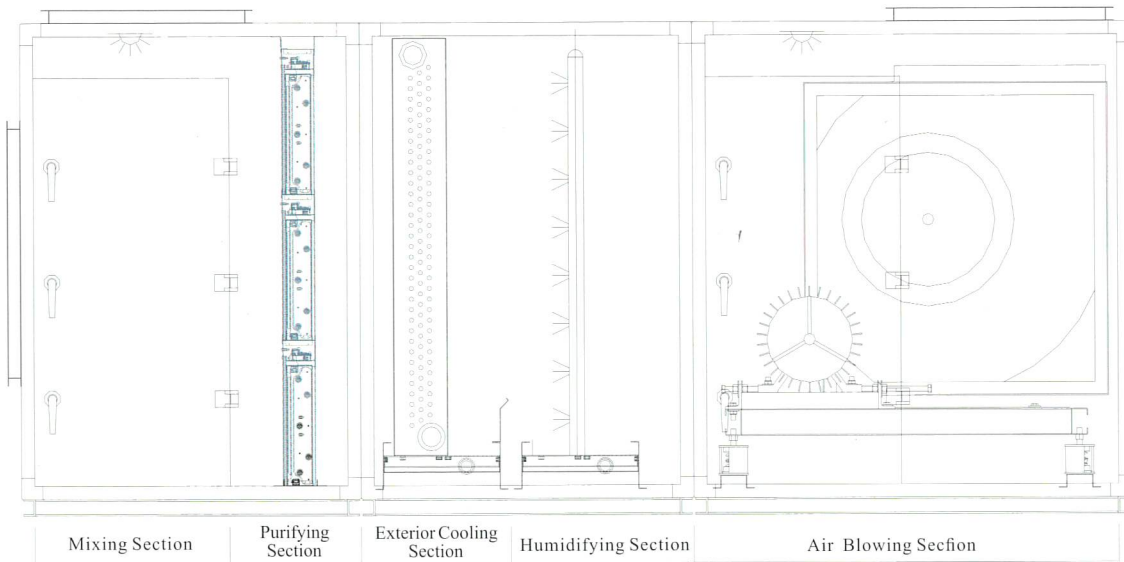

▲ Installation

Air duct type electrostatic air purification and disinfection device

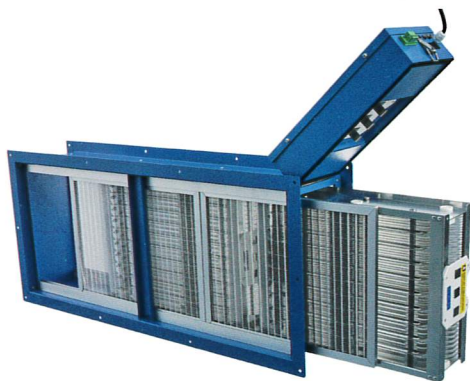

■ Total purification

This product effectively removes suspended particles from the air, including TSP (Total suspended particles), PM10, PM2.5, cigarette smoke, pollen, bacteria, spores, and dust mites. It can effectively remove more than 95% of PM2.5 particles at one time, and achieve a microbial killing rate of more than 90% underrated air volume. In addition, it can effectively capture ultra-fine particles with a diameter of 0.1 μm.

■ Widely used

The product is suitable for AHU (air handling unit) and PAU (fan coil unit) in commercial central air conditioning systems, as well as large transportation hub systems, medical systems, large sports and sports systems, and large business centers with high indoor air quality requirements.

■ Perfect function

The product has a wind-sensing start function which can start operation according to the air volume, you can also choose remote start. It also has functions such as operation, cleaning, and fault alarm, and can interface with the building automation (BA) system to facilitate maintenance of equipment.

■ Simple installation

The product can be installed at the primary air inlet or return air duct of the air conditioning unit, with its own flange, can be seamlessly connected with the air duct, and the installation is relatively simple.

Products Parameter

Product name	Product Model	Air volume (m³/h)	Product size(mm)			Power (w)	Weight (kg)	PM2.5	Microbial	Resistance (Pa)	Operating voltage	Working environment
			W	H	L							
Air duct type electrostatic air purification and disinfection device	AP-E-FD-1200	1000	398	249	185	15	8	≥90%	≥95%	≤30Pa	AC 220V 50Hz	Temperature: 1~50℃ Humidity : ≤95%
	AP-E-FD-1500	1300	398	330	185	15	10					
	AP-E-FD-2000	1600	398	411	185	15	13					
	AP-E-FD-1500	1250	508	249	185	15	9					
	AP-E-FD-2000	1700	508	330	185	15	11					
	AP-E-FD-2500	2100	508	411	185	15	14					
	AP-E-FD-3000	2400	718	330	185	15	13					
	AP-E-FD-3500	3000	718	411	185	20	15					
	AP-E-FD-2500	2000	808	249	185	20	11					
	AP-E-FD-3000	2500	808	330	185	20	15					
	AP-E-FD-4000	3300	808	411	185	20	19					
	AP-E-FD-5000	4200	808	525	185	35	23					
	AP-E-FD-4000	3400	1027	330	185	20	20					
	AP-E-FD-5000	4200	1027	411	185	25	25					
	AP-E-FD-6500	5500	1027	525	185	40	30					
	AP-E-FD-8000	6500	1027	633	185	50	36					
	AP-E-FD-5000	4000	1252	330	185	25	24					
AP-E-FD-6000	5000	1252	411	185	30	30						
AP-E-FD-8000	6500	1252	525	185	50	33						
AP-E-FD-10000	8000	1252	633	185	50	40						

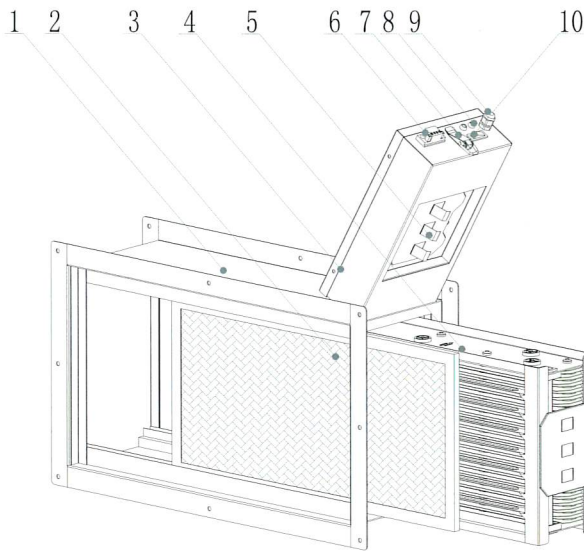

- 1-Air duct
- 2-Front filter
- 3-Electric control box
- 4-Electrostatic ion box
- 5-Ion contact shrapnel
- 6-BA signal terminal
- 7-Clasp
- 8-Status indicator light
- 9-Power input wire
- 10-switch

▲ Product structure

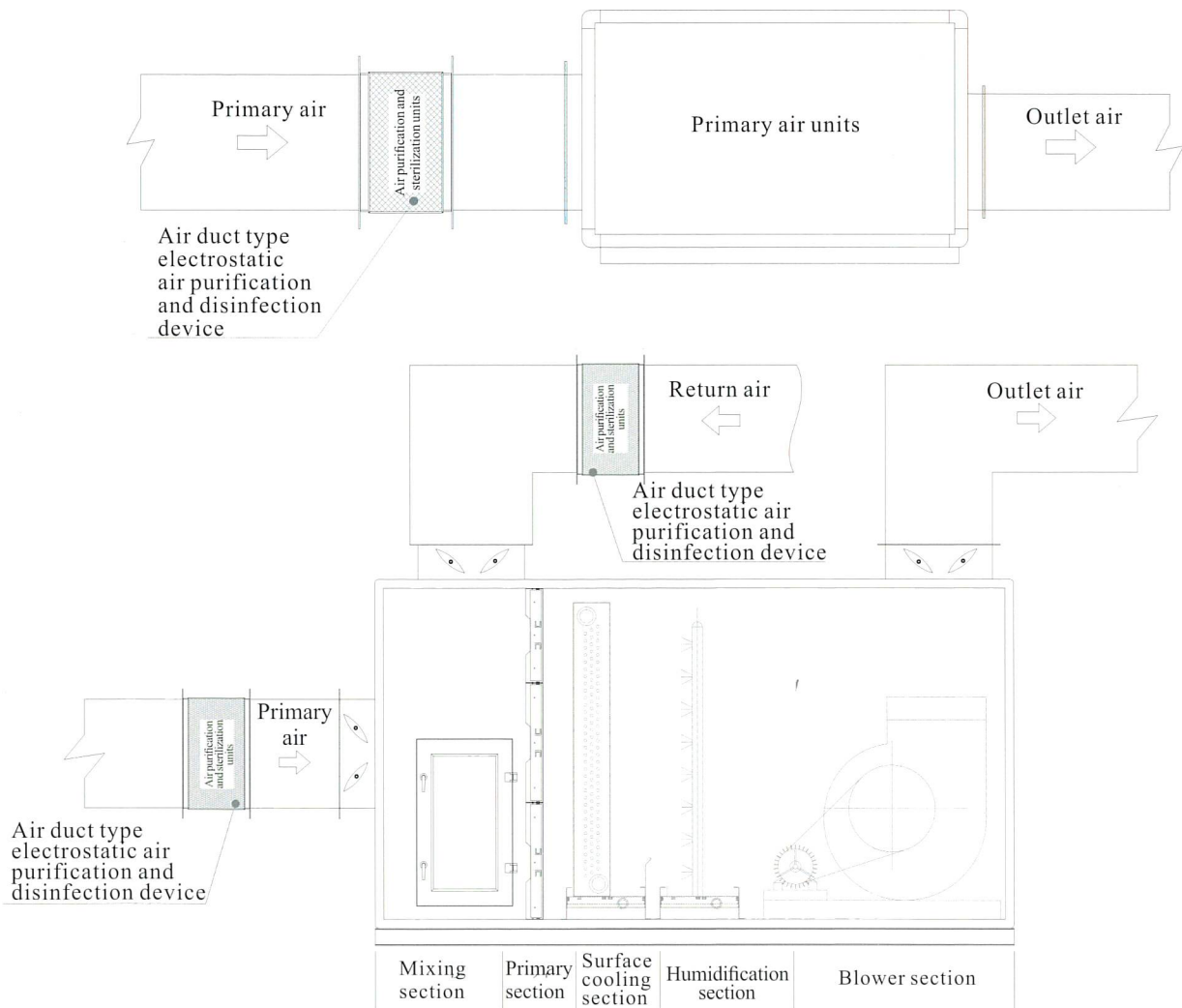

▲ Installation

Air duct Type Photocatalytic Air Sterilization Treatment Unit

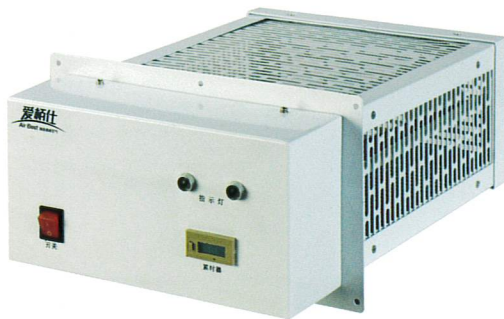

Low carbon and energy saving

When the wind speed is $\leq 2.5\text{m/s}$, the product resistance is $\leq 15\text{Pa}$, which effectively reduces the energy consumption of the system while ensuring the indoor air quality.

Comfortable and reliable

The decomposers are CO_2 and H_2O , which will not cause secondary pollution to the air. The negative ions have a calming effect on the human nervous system, eliminate fatigue and increase human comfort.

Comprehensive sterilization

Kills bacteria more thoroughly, effectively killing hundreds of disease-causing microorganisms in the air and decomposing toxic and harmful gaseous pollutants such as formaldehyde, benzene, and TVOC in the air.

Wide range of applications

The products are suitable for AHU and PAU commercial central air-conditioning systems, large transport hub systems, medical systems, large cultural recreation and sports systems, large commercial/business centers and other places that require high indoor air quality.

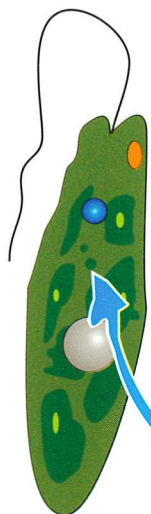

Light wave spectrum

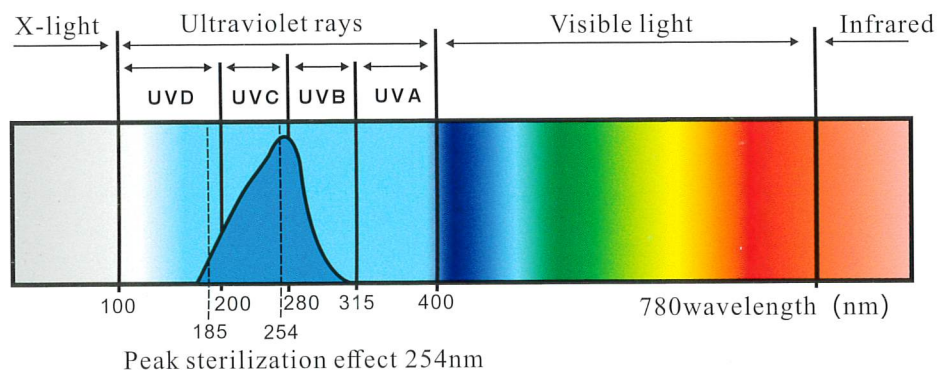

UV-C Light

The best sterilizing effect was wavelength at 254nm

Products Parameter

Product name	Product Model	Air volume (m ³ /h)	Product size (mm)			Power (w)	Weight (kg)	Gaseous Pollutant	Microbial	Resistance (Pa)	Operating voltage	Working environment
			W	H	L							
Air duct Type Photocatalytic Air Sterilization Treatment Unit	AP-S-FD-3000/II	2000~4000	335	195	315	12	7	≥90%	≥95%	≤10Pa	AC 220V 50Hz	Temperature: 1~50°C Humidity: <95%
	AP-S-FD-7000/II	4000~10000	335	195	435	20	8					
	AP-S-FD-15000/II	10000~20000	480	295	435	30	13					
	AP-S-FD-25000/II	20000~30000	480	295	545	45	17					

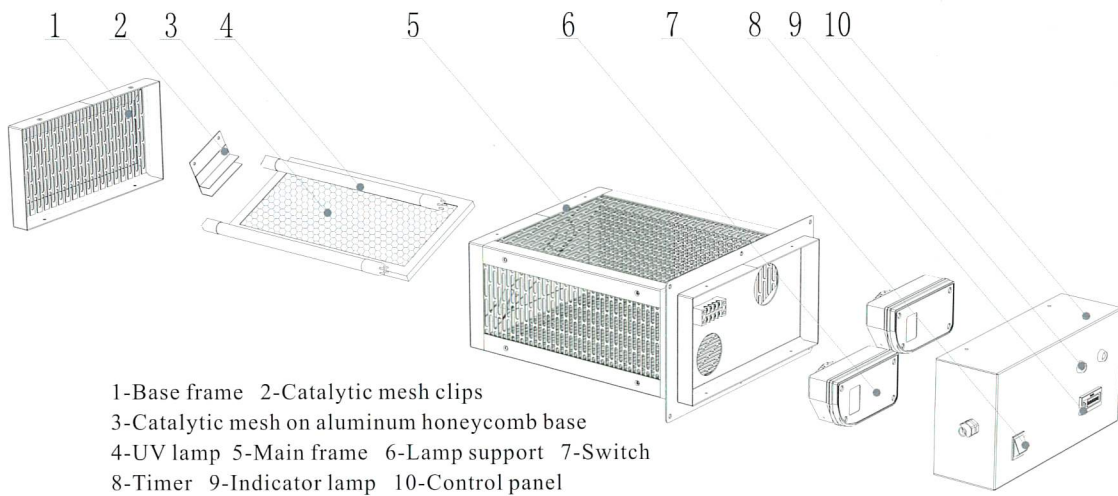

▲ Product structure

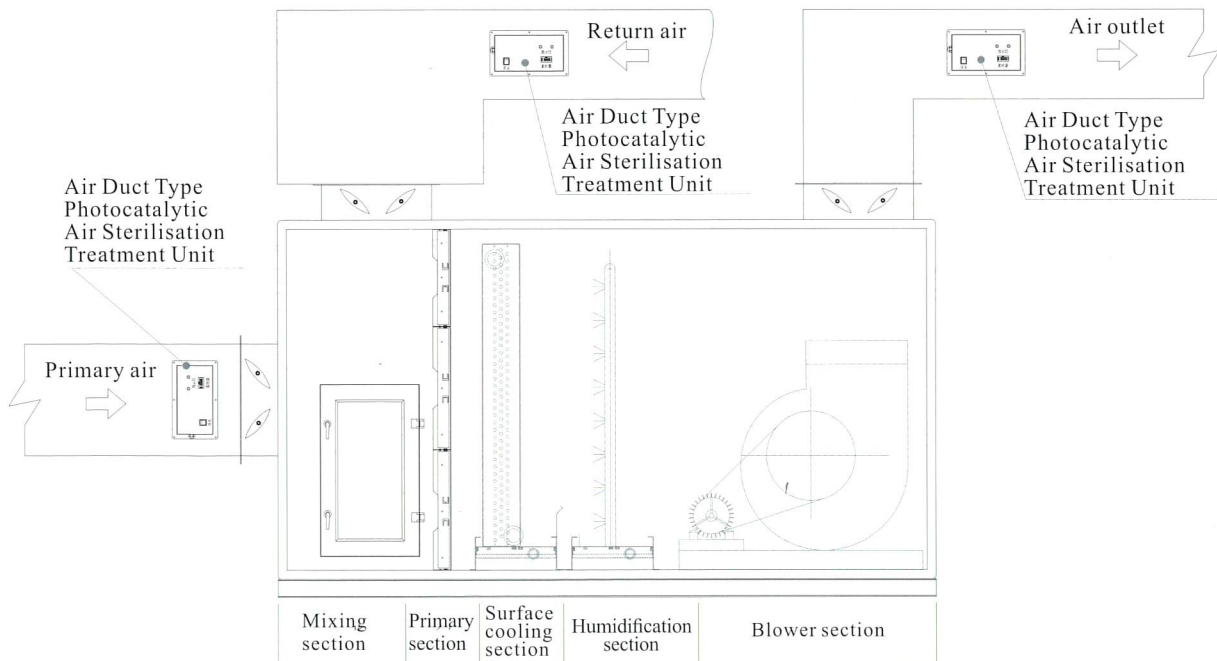

▲ Installation

Return bellows type electrostatic air purification and disinfection device



Perfect fit

The product can be installed at the fan coil unit of the central air conditioning system. The product can be selected according to the fan coil type and the way of the return bellows type, making the installation more flexible.

Product configuration

The product can be synchronized with the fan coil to on and off, also wind-sensor on, or optional remote start. It has the functions of operation, cleaning, fault alarm, etc., and connects with the building BA system to convenient for users to maintain the equipment.

Efficient purification

Remove suspended particulate matters effectively (TSP, PM10, PM2.5, cigarette smoke, pollen, bacteria, spores, dust mites, etc.) The one-time effective removal rate of PM2.5 reaches more than 95%, and the microorganism killing rate reached above 90% at a rated air volume, effectively capture ultrafine particles with a diameter of 0.1 μm .

Low carbon and energy saving

Resistance loss $\leq 10\text{Pa}$, which effectively reduces the energy consumption of the system while ensuring indoor air quality.

Economical and practical

The dust collection module is made of aviation aluminum, and the outer frame is made of aluminum and zinc plates with special surface treatment, which effectively prevents equipment from rusting. Also, the equipment materials are recyclable.

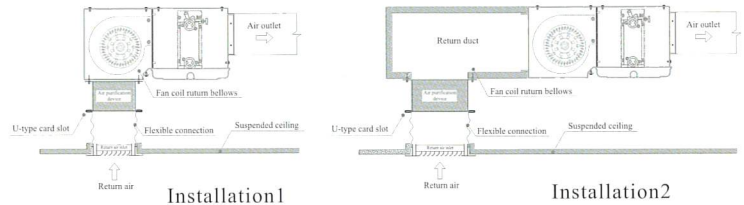

Installation

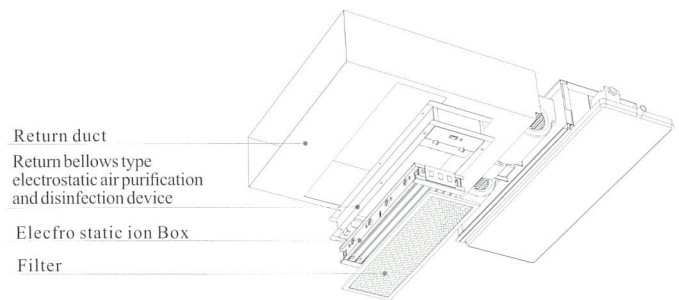
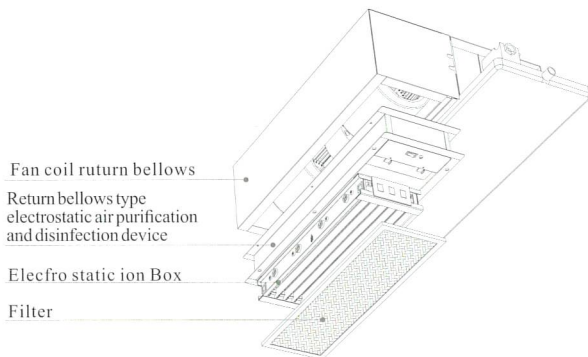

Installation

Products Parameter

Product name	Product Model	Air volume (m ³ /h)	Product size(mm)			Power (w)	Weight (kg)	PM2.5	Microbial	Resistance (Pa)	Operating voltage	Working environment
			W	H	L							
Return bellows type electrostatic air purification and disinfection unit	AP-E-FP-03B	500	590	241	85	10	4	$>90\%$	$\geq 95\%$	$< 10\text{Pa}$	AC 220V 50Hz	Temperature: 1~50°C Humidity: $< 95\%$
	AP-E-FP-04B	680	740	241	85	10	5					
	AP-E-FP-05B	850	820	241	85	10	6					
	AP-E-FP-06B	1020	1020	241	85	10	7					
	AP-E-FP-08B	1360	1250	241	85	10	8					
	AP-E-FP-10B	1700	1320	241	85	15	9					
	AP-E-FP-12B	2040	1480	241	85	15	11					
AP-E-FP-14B	2380	1710	241	85	25	12						

High effectiveness

Achieves a killing rate of over 95% for bacteria and microorganisms in indoor air circulation. Effectively treats harmful organic gases like formaldehyde, benzene, and TVOC, with a removal rate of 90%.

Better design

Incorporates a guide plate design that optimizes airflow, slowing down wind speed and extending contact time with ultraviolet and photocatalytic materials. This design ensures comprehensive sterilization and catalysis. Additionally, the shading plate design effectively reflect and shades special spectral light leakage, prioritizing the elimination of ultraviolet light leakage.

Simple installation

The fan coil-type nano photocatalytic air handling device features a two-stage design that makes installation easy. It offers two installation options, and placing the lamp inside the air duct maximizes efficiency. Furthermore, installing the base outside the air duct effectively prevents condensation.

User-friendly operation

Enables linkage operation with the fan, simplifying equipment main tenance for the user.

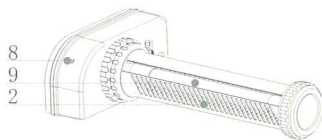
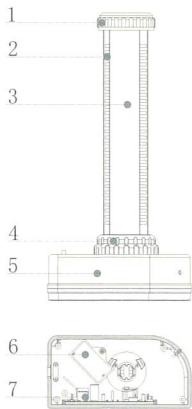

- 1-Top cap
- 2-Air deflector
- 3-Visor
- 4-Fixed cover
- 5-Pedestal
- 6-Anion
- 7-Ballast resistor
- 8-Pilot lamp
- 9-Dual band UV lamp

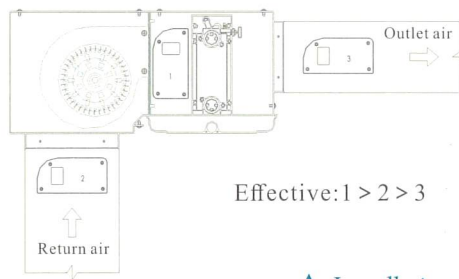

Effective: 1 > 2 > 3

▲ Product structure

▲ Inatallation

Light wave spectrum

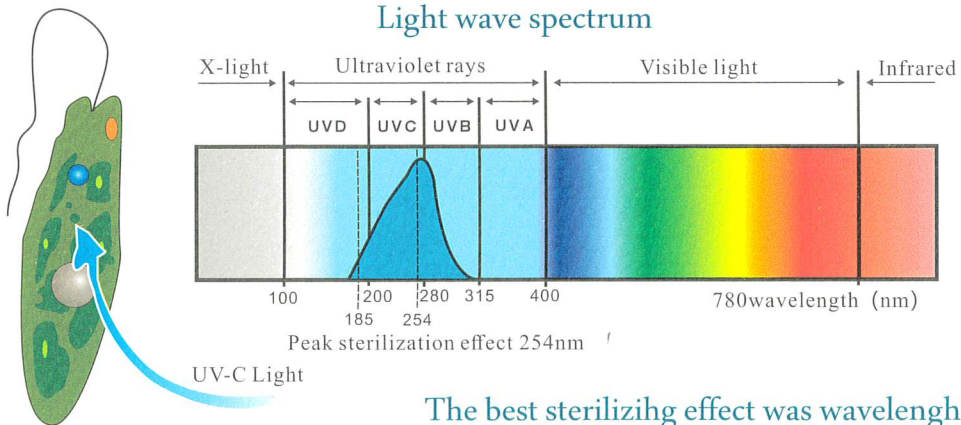

The best sterilizing effect was wavelength at 254nm

Products Parameter

Product name	Product Model	Air volume (m³/h)	Product size(mm)			Power (w)	Weight (kg)	Gaseous Pollutant	Microbial	Resistance (Pa)	Operating voltage	Working environment
			W	H	L							
Photocatalysis Air Sterilizing device	AP-S-FP-E	300~675	142	72	275	6	0.45	≥90%	≥95%	≤10Pa	AC 220V 50Hz	Temperature: 1~50°C Humidity: <95%
	AP-S-FP-F	675~1015	142	72	275	6	0.45					
	AP-S-FP-G	1015~1525	142	72	400	10	0.5					
	AP-S-FP-H	1525~2040	142	72	400	10	0.5					

The models and specifications published in this catalog are subject to change without prior notice due to product updates.

Although this catalog has been proofread multiple times for accuracy, it is for reference only and everything is subject to the actual product.

NingBo AIPRO Environmental Technology Co.,Ltd

Add: No. 1, South Section of Chuangqing Road, Shiqi Street,
Haishu District, Ningbo City, Zhejiang Province, China

TEL: (+86-574)88152631

FAX: (+86-574)88152551

Service Hotline: 400-8866-578

Web: [Http://www.nbairbest.com.cn](http://www.nbairbest.com.cn)

